

EKFGV1102

Chimney connection set 60/100 Air intake Dn.80 C53

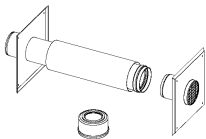

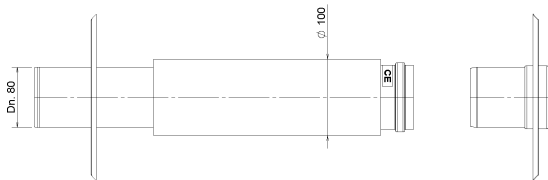

14 00748 00a

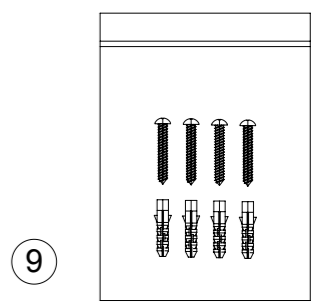
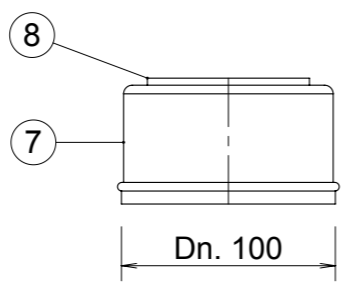
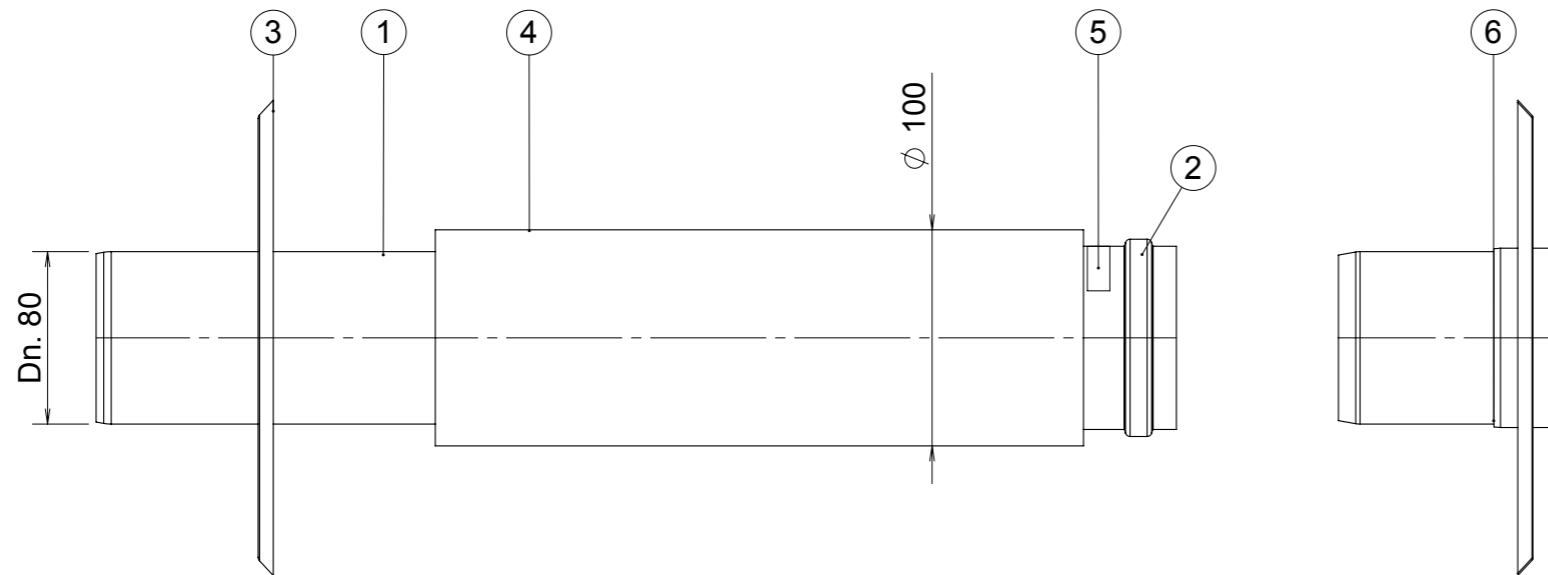
REV.NR.	REVISION DESCRIPTION	BY	PROJ. NR.	DATE
00	First Release	J.W.Kooi		08/04/2014

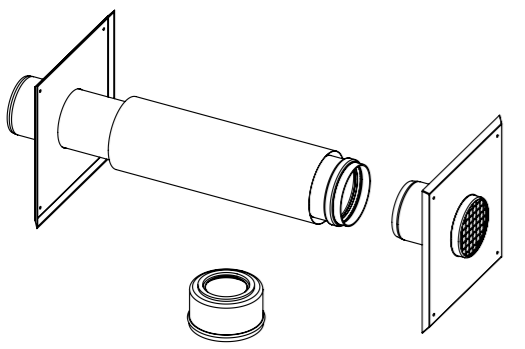

POS.	QTY.	DESCRIPTION	DRW.NR.
9	2	SET BEV.MATERIAAL 4.2x32 (4 STUKS)	93 1018
8	1	SP. RING 1-LIPS SIL. Dn.57 BL.	93 0012
7	1	AFSL.DOP AL 100 H=55 +GAT 60	08 0863
6	1	M2000 1-PIJPS MDV LT 80	93 1433
5	1	CE-PRD.STICKER 0.1 119933 EW-AL	93 0294
4	1	PIJP GALV. 0.4 Uitw. 100 L=300	93 0087
3	1	MUURAFD.PL.AL. 220x220 1 GAT 81	93 0567
2	1	PR. RING 2-LIPS SIL. 80 BL.	93 0006
1	1	M.FIX PIJP 80 L1=500	93 0266

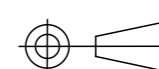

DESCRIPTION	SCHOORSTEEN AANSLUITSET 60/100 C53				DEFINITIVE		
REMARK	DAIKIN						
 <small>ALL RIGHTS RESULTING FROM THIS DESIGN, ARE RESERVED TO THE M&G GROUP</small>	DRAWN	J.W.Kooi	Units in mm. Tolerances:(unless otherwise specified)	TOOL.NR.	MATERIAL	ALUMINIUM	
	DATE	17/07/2013	Holes: ±0.1 Angles: ±1° Other: ±1	SCALE	1:3.5	SPEC. NR.	
	PROJ. NR.	P-14238		SHEETSIZE	A3	DRAW.NR.	14 00748 00
	CHECKED	Hendry Meijer		SHEET NR.	1 / 1	ART.NR.	41.012.11.02